

MHB SL30-ISO® Profile system

30 mm / 1 3/16" width | 100+ Years Service Life Prediction | Solid steel profiles



Overview

With centuries of expertise in steel mastery, we have developed a unique, solid steel profile. Our SL30-ISO® profile combines the superior strength of solid steel with a high-tech thermal break, resulting in an ultra-slim, exceptionally durable profile. Its superior performance requires a width of only 30 mm / 1 3/16", giving architects the freedom to design revolutionary architectural landmarks of ingenuity and innovation.

- Patented profile system with unique 30 mm / 1 3/16" sightlines, providing unrivaled design freedom.
- MHB is the exclusive developer and manufacturer of all its steel profile systems, allowing for optimal adaptability and quality control.
- Outstanding thermal insulation certified according to European NEN-EN ISO standards and American NFRC standards
- Extreme durability with a predicted service life of over 100 years.
- Customizable true divided or simulated divided glass partitioning and glass stops.
- Create harmony with consistent detailing for all configurations in your project.
- Available in any RAL color or actual precious metals such as bronze for a unique and durable finish.

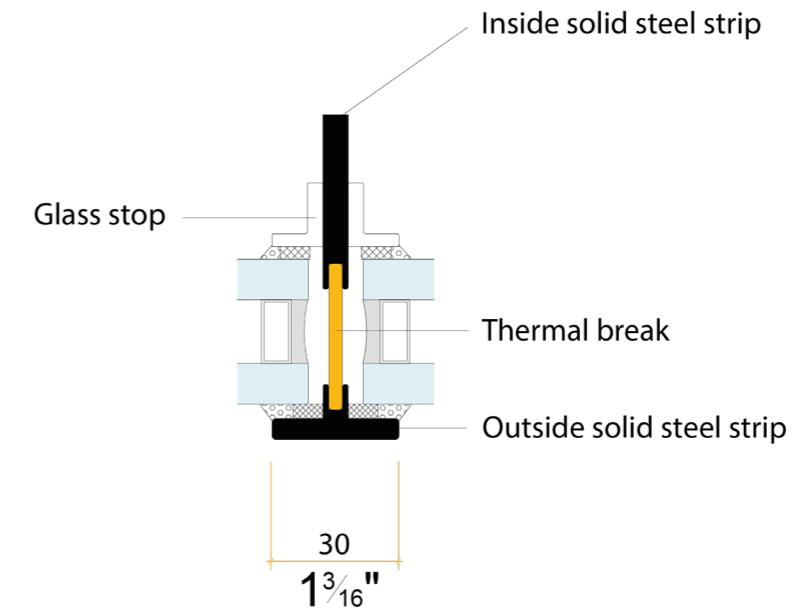

Unrivaled freedom to design

MHB is the exclusive developer and manufacturer of all its patented profile systems, which allows us to improve and adapt our products on a project-specific basis. If you have any project-specific needs or wishes, please let us know and we will work with you to create the optimal solution:

- Custom detailing.
- Custom oversized window & door dimensions.
- Automated systems.